

Make cone a little longer than you need it, ie. with the small diameter smaller and the large end larger. You can always cut it down to the required size. Dont try to be too exact!

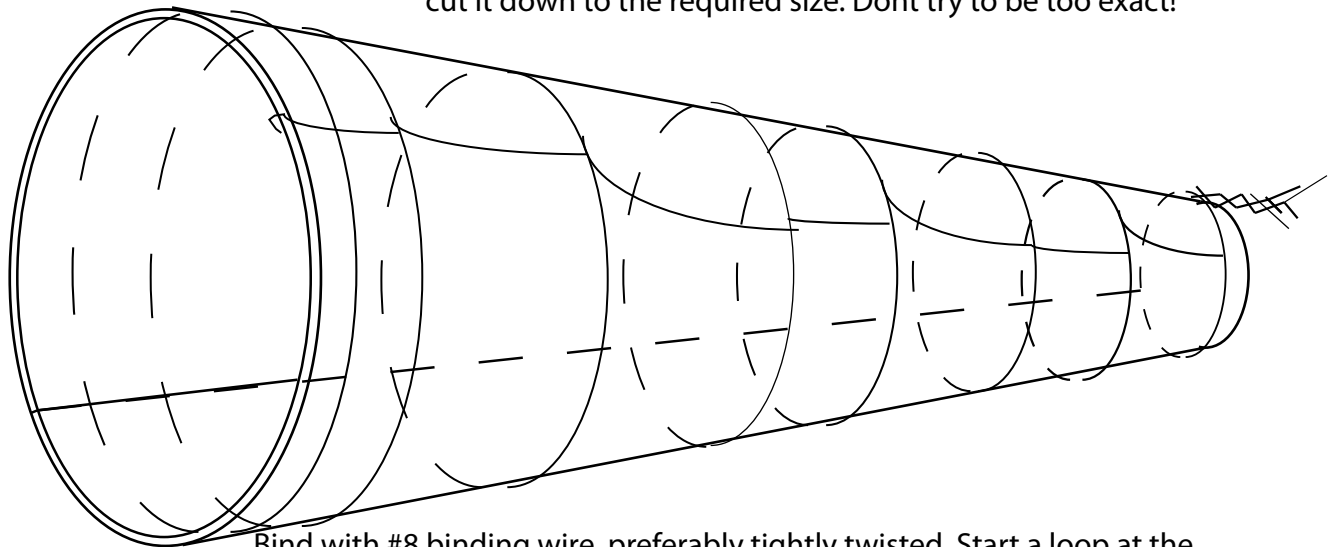

Bind with #8 binding wire, preferably tightly twisted. Start a loop at the small end then continue tightly looping every 15mm till the large end. Then fold the end back into the cone to hold the loops in place.

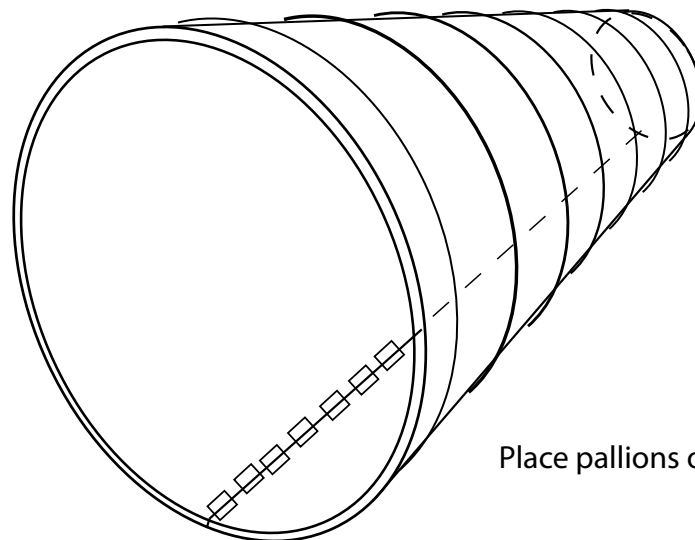

Place pallions of hard solder on joint.